

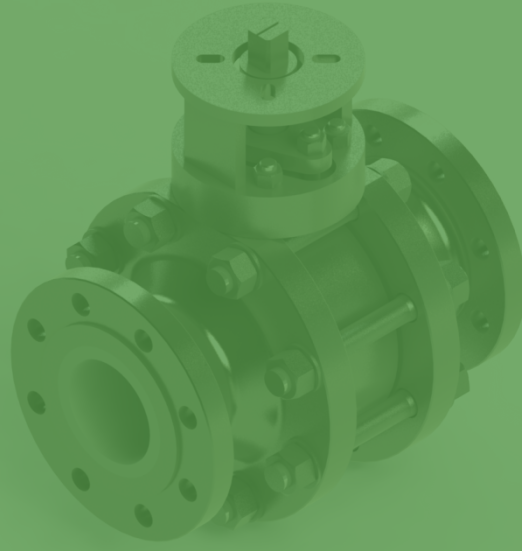

CERIUM STABILISED ZIRCONIA

PED

LEAKAGE CLASS V



ASME B16.34

HiLife

Fine Ceramic Ball Valve

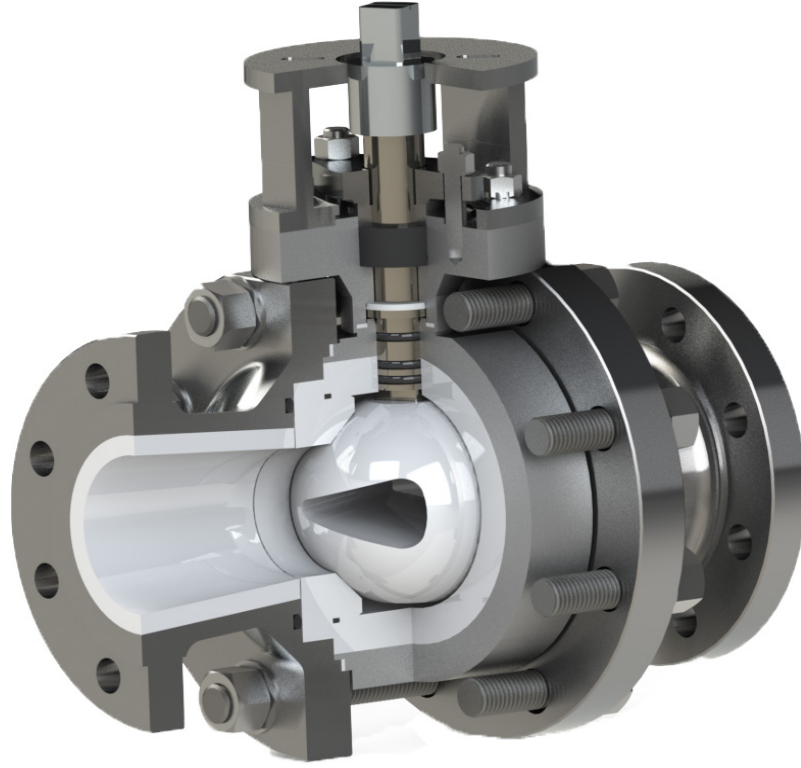

PN 16

ISO9001

PAGE

- 2 About Carten Controls Ltd
- 3 Why Choose a Carten HiLife Ceramic Ball Valve
- 4 HiLife Technical Specifications
- 5 Typical Applications

- 7 Exploded View
- 9 Specifications, Dimensions & Cv Values
- 11 Ceramic Spools, Adaptors & Reducers
- 12 Instrumentation & Accessories
- 13 HiLife Product Description
- 14 Customer Order Requirements

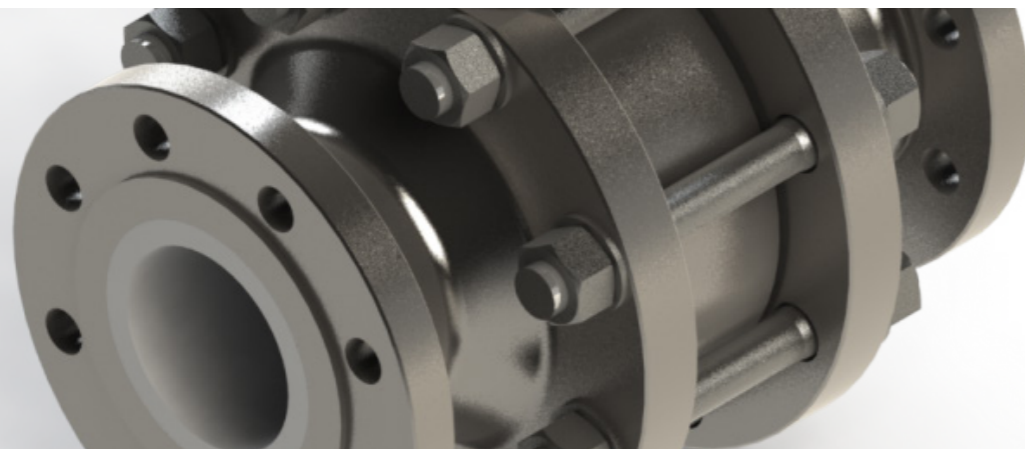

About Carten Controls



Carten Controls has been a member of the Fujikin Group (FCG) since 1991. Carten, through the Fujikin Group, are the pioneers of the ceramic ball valve. The ceramic (Cosmix) series was developed by Fujikin in 1975, with tens of thousands units of ceramic valves sold. The reputation of customers confirms our record as the highest quality in the market.

Carten has developed the HiLife Ceramic series to adapt to ever increasing challenges from industries that require solutions to abrasive high pressure applications, extreme component wear, erosive and corrosive media, in particular fine powder application (PCI, TiO₂, and Polysilicon) where higher life and wear is a requirement from valve performance. Taking into consideration the frequent maintenance and replacement costs required of alternative severe-service valves, the HiLife substantially improves on overall service life, accuracy and control and reduces the total cost of ownership in abrasive, erosive and corrosive systems.

Carten valves are utilised globally in a wide variety of applications and systems in the most demanding industries. These include bulk gas delivery, lateral distribution systems, filter-skids, purifiers, valve manifold boxes (VMBs), valve manifold panels (VMPs), gas panel, solvent, hook-up and gas cabinet applications. Together with Fujikin, Carten design and manufacture customised media flow solutions by utilising products from Carten-Fujikin's global network that deliver efficiency, reliability, safety and performance to specification and global standards. Carten-Fujikin have developed design and manufacturing knowledge in ceramic valves for severe service systems that deliver reliability, safety, performance and lower total cost of ownership in abrasive, erosive and corrosive industries.

Carten has grown considerably and is firmly established as a leading and innovative valve supplier to blue-chip global customers in the semiconductor, LED, photovoltaic and LCD markets.

Our commitment to our customers and quality is demonstrated through our on-going membership and certification to the IS EN ISO9001 standard and PED certification by the implementation of continuous improvement initiatives throughout the company.

The company have expanded in line with industry demands and have invested heavily in new production capabilities. These include CNC machining, surface finishing, welding, electropolishing and high-specification cleanrooms to ISO4, ISO5 and ISO6 standards.

Carten Controls' core product line includes high-purity bellows, diaphragm, check and ball valves and pharmaceutical diaphragm valves. We manufacture gas-pressure regulators, dual-containment valves, vacuum generators, and ceramic and control valves in our state-of-the-art facilities in Ireland and the USA.

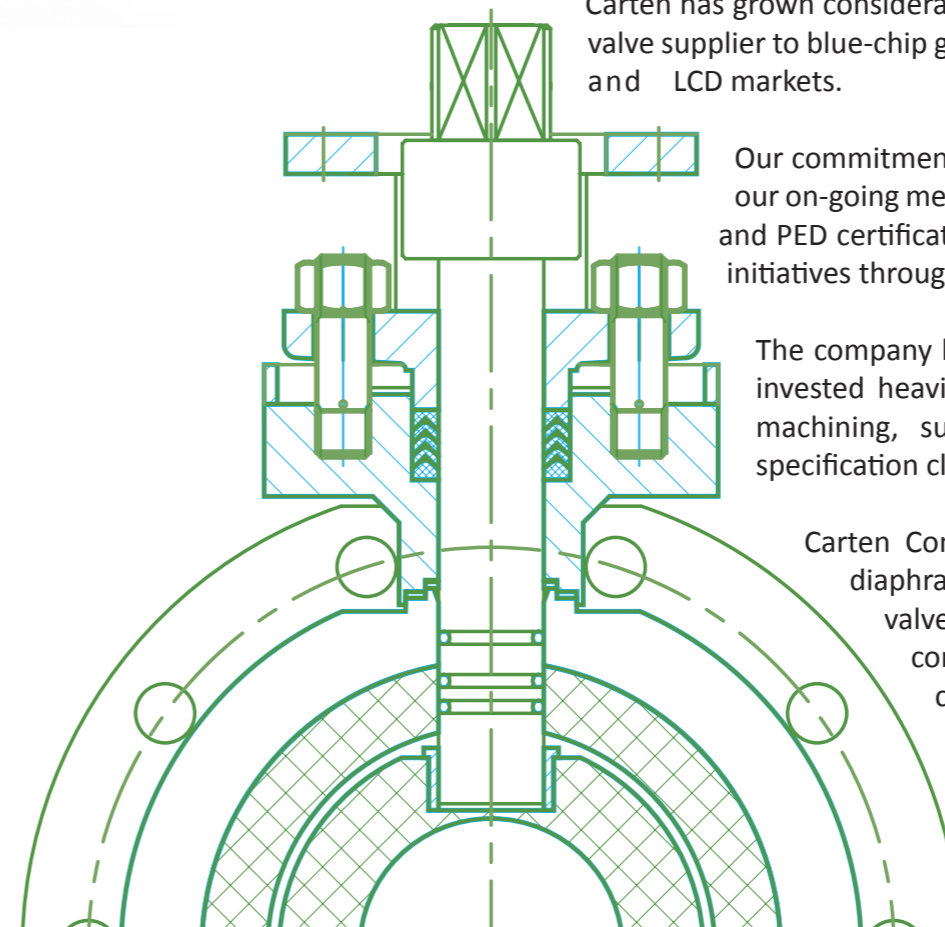

Why Choose a Carten HiLife Ceramic Ball Valve?

Ceramics are:

Corrosion-Resistant: Ceramics do not react with most chemicals, including strong acids and alkalis.

Abrasion Resistant: Ceramics are almost equivalent to diamonds in terms of hardness and they are highly resistant to wear.

Cavitation Resistant: Unlike stainless steel, they can handle continuous cavitation without cracking or wearing down.

Ceramics are **not affected by changes in the pressure** across the valve.

Zirconia along with a number of other materials offers **high thermal shock resistance.**

Serialised Valves as standard to ensure traceability to all production records, raw material, chemical and mechanical composition data.

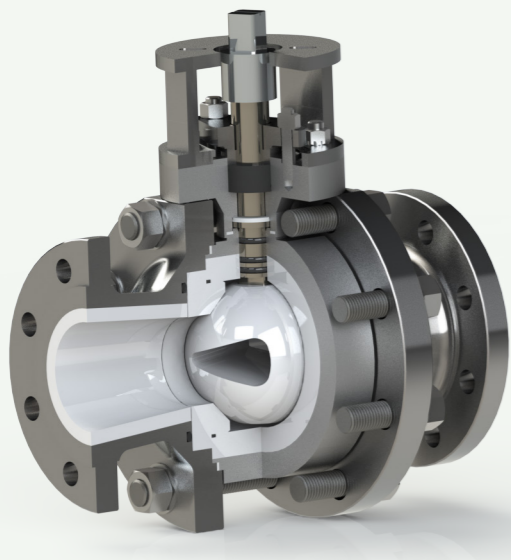

Figure 1: Hardness Comparison

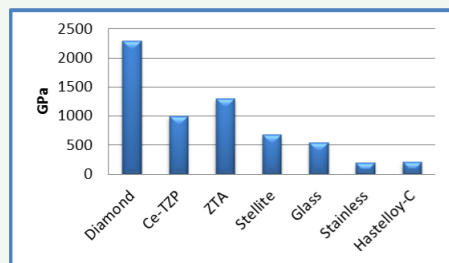

Figure 2: Fracture Toughness Comparison

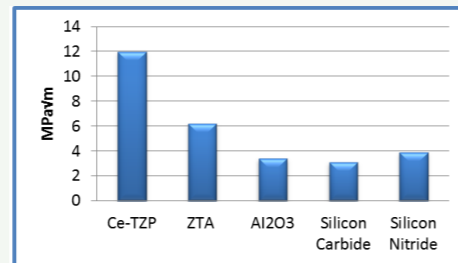

Figure 3: Flexural Strength Comparison

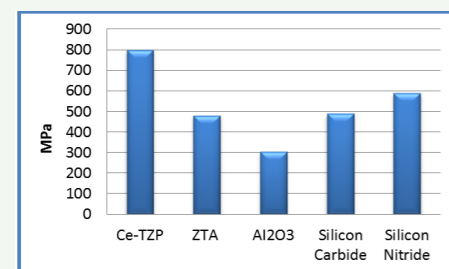
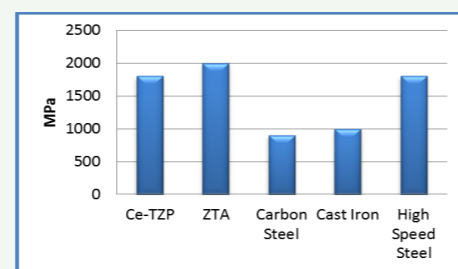

Figure 4: Compressive Strength Comparison



PROPERTIES OF CERAMICS

Property	Units	Materials	
		Cerium Stabilised Zirconia	Zirconia Toughened Alumina
Colour	-	Ivory	Ivory
Bulk Density	g/cm ³	5.6	4.2
Water Absorbency	%	0	0
Hardness	Kgf/mm ²	850	1300
Flexural Strength	MPa	1150	480
Compressive Strength	MPa	1850	2000
Thermal Conductivity @ 20°C	W/mk	2.7	22
Fracture Toughness	MPa√m	10	5.5
Maximum Use Temperature (in valve)	°C	200	200
Thermal Shock Resistance	°C	<200	<250
Young's Modulus of Elasticity	GPa	207	320
*Coefficient of thermal expansion	200 °C (*10 ⁻⁶ /°C)	9-11	7-8

HiLife Key Specifications

Maximum Pressure Rating	PN16 (16 BAR/232PSI)*
Leakage Class	ANSI FCI 70/2 Class V **
Maximum Temperature	200 °C/392°F ***
Max Differential Temperature	100 °C/210°F
Standard Ceramic Ball	ZrO ₂ -Ce-TZP
Standard Ceramic Lining	ZTA (Zirconia-Toughened Alumina)
Flow Control	Shut-Off + EQ%
Overall Dimension	EN558-1 OAL
Integrated Reducers	Yes
Internal Bores	DN Full Bore Sizing
Ceramic Parts Interchangeable	Yes
Certification	Certified as per PED Module D1 (Up to category 2)
Stem Design	Blow out proof as per ASME B16.34

*PN16 is the standard rating of the HiLife Series, contact Carten for further options

** ANSI Class VI available on request

***If the temperature is to be constantly varied and the differential temperature is more than that allowed, a step by step gradual increase/decrease must be strictly adhered to. This avoids possible damage to the valve ceramics.



HiLife Key Features

The Carten HiLife series provides an air tight seat closure seal, featuring reduced space between the ball and socket ceramic seat seal. Unique design features provide additional seat sealing compression advantage at lower pneumatic pressure required, for example, with the dilute pneumatic convey process.

Zirconia ceramic parts offer greater resistance against wear for any fine particles that attempt to interfere with the ceramic seals.

Flat-faced ceramic seal at the valve flange outlets is standard – therefore ensuring that the seals used will prevent immediate leakage to atmosphere if the ceramic cracks.

The stem sealing system protects against over-pressurisation of any system through a blowout proof sealing feature.

The HiLife series also allows pressurisation from both sides, retaining the same leakage class performance.

The Carten HiLife Ceramic Ball Valve has been developed to react to new challenges in industries that require solutions to abrasive and corrosive media, in particular fine powder application including:

1. Polysilicon Processing
2. Pulverised Coal Injection (PCI) and
3. Titanium Dioxide (TiO₂)
4. Copper Mining
5. General Mining
6. Chemical Industry
7. Paper & Pulp
8. FGD
9. Milk and more..

Zirconia-Toughened Alumina is used in all stationary ceramic components for the Carten HiLife Ceramic Ball Valve due to its high resistance to wear and abrasion. As the ceramic ball needs to be extremely strong, wear-resistant, chemically inert, have a fracture toughness of a high level, and resistance to degradation at low temperatures, Cerium-stabilised Zirconia is utilised. Dead Space is also reduced in this ceramic valve ensuring that aggressive fine particles are not lodged in any cavity – thereby avoiding any crystallisation causing cracking to ceramic components. The HiLife Series is available from ½" up to 6" line sizes (DN15-DN150) and is provided with air tight Class V seat leakage classification (Class VI on request). Taking into consideration the frequent maintenance and replacement costs required of comparative severe-service valves, the HiLife clearly improves on overall service life, accuracy and control and reduces the total cost of ownership in abrasive, erosive and corrosive systems.

Polysilicon Processing

The Carten HiLife Ceramic Ball Valve is suitable for polysilicon processing as it is encompassing of the following features:

1. The additional seat sealing compression in the HiLife Ceramic Ball Valve is an advantage at lower pneumatic convey pressure of Silica production.
2. The reduced dead space in the valve ensures the aggressive Si fine particles are not lodged in any cavity – thereby avoiding any crystallisation of Si powder causing cracking to ceramic components.

3. The Zirconia-Toughened Alumina used for all ceramic stationary components, possesses greater resistance to abrasion than Alumina. For the silica processing industry at this stage – abrasion is more important than corrosion

4. The flat-faced ceramic seal at flange outlet of the HiLife ceramic ball valve is standard – therefore ensuring that the seals used will prevent immediate leakage to atmosphere if the ceramic cracks. HCl gas can react with moisture in the atmosphere to form hydrochloric acid.

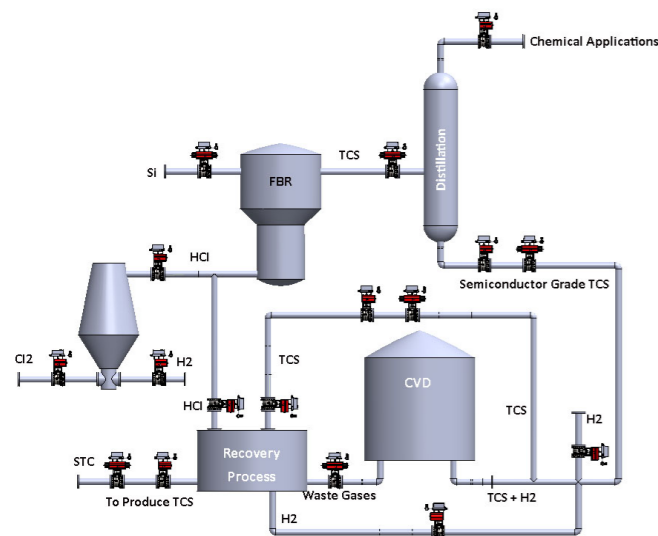

Pulverised Coal Injection (Steel Plant Applications)

Injection of carbon powder in electric arc furnaces (EAF); Raw iron desulphurisation (supply of additives: CaC, MgO₂...)

Carten recommend the installation of the Hi-Life series in PCI applications, for the following reasons:

1. The PCI industry can utilise pressure of up to 16-17 BAR depending on the pneumatic convey process type selected; Dilute Phase or Dense Phase.
2. Moisture content of coal particles can cause sticking and handling problems – the zirconia material used in the HiLife series can withstand higher torque than other ceramic ball valves.
3. When fine particles are processed they require less dead space and Class V leakage rates which are featured in the HiLife Series.
4. Zirconia is a harder material than Alumina, which is critical depending on the type of coal used for PCI.

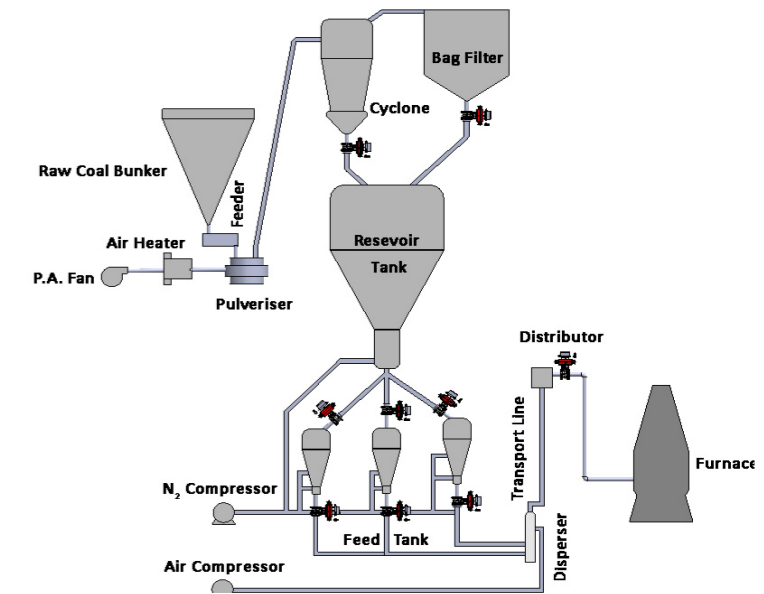

Titanium Dioxide (TiO₂)

Titanium dioxide is now the common white pigment in paints after the use of lead oxide was banned some years ago. The overall process of manufacture is to take an impure TiO₂ feedstock and to convert this into pure white TiO₂ pigment. Once titanium containing ores have been mined, they are converted into pure titanium oxide. The two main production methods are the sulphate process and the chloride process.

Carten recommend installation of the HiLife series in TiO₂ applications, for the following reasons:

1. The TiO₂ industry utilise generally low pressures of 5-7 BAR depending on the process type selected.
2. Class V leakage is often required depending on the area of install, and the type of process used. For the chlorine method, HiLife is suited when processing gaseous or solid forms of process media.
3. The particular abrasion of finer TiO₂ particles make the Carten HiLife model more suitable due to the Class VI leak rate.

Flue Gas Desulphurisation (FGD)

FGD plants remove sulphur and nitrogen oxides (released during the burning of fossil fuels) minimising pollution in the atmosphere, using a wet or dry alkali reagent.

Carten recommend the installation the HiLife series in FGD applications, for the following reasons:

1. Floating ball concept – suits slurry media with low rotational forces necessary to move ball, reducing possibility of fracture
2. Raised ceramic face allows for minimum torque during installation
3. Wide array of available ball trims and flow curves

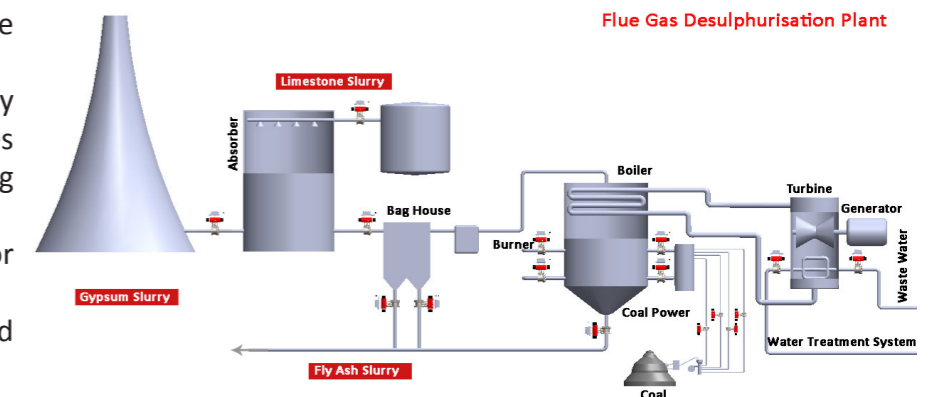

1 Stainless Steel Bolts & Nuts provides the ideal combination of strength and corrosion resistance to meet industry needs

2 Zirconia-Toughened Alumina Lining fitted to every inlet and outlet piece of the HiLife series to ensure maximum protection for end users piping systems against wear, corrosion, abrasion, and erosion. The flange steel component (3, below) effortlessly absorbs the adjustment forces, the ceramic lining ensures efficient wear protection

3 Stainless Steel Body Flange offers excellent corrosion-resistant properties and design strength to secure the appropriate leak-tightness specification, and allows the valve to be exposed to extremely harsh environments without external corrosive degradation. It securely encloses the ceramic components and protects them from any possible damage. Pipe stresses are not transferred to the ceramics but are absorbed by the stainless steel flange and body of the valve.

4 Zirconia-Toughened Alumina Ball Socket ensures increased mechanical strength and fracture toughness over alumina. ZTA has a high temperature stability and corrosion resistance.

5 Stainless Steel Body allows the valve to be exposed to extremely harsh environments without external corrosive degradation. It securely encloses the ceramic components and protects them from any possible damage. Pipe stresses are not transferred to the ceramics.

6 Stainless Steel Bonnet Flange offers excellent corrosion-resistant properties and design strength to secure the appropriate leak-tightness specification, in addition to compressing against the machined one-piece hastelloy stem lip - therefore providing a blow-out proof design feature

7 Stainless Steel Bracket meets the dimensional standards of ISO 5211 – which is the basis for a sturdy, clean, direct-fit onto most rotary actuator brands and models. This mounting pad may be removed to permit special automation packages, thus making the HiLife valve very automation-friendly. DIN 3337 version available upon request.

8 Stainless Steel Coupling meets ISO 5211 square-drive actuator dimensions – which is the basis for a sturdy, clean, direct fit onto most rotary actuator brands and models. DIN 3337 version available upon request.

9 O-Rings are kept energized without the need for periodic packing re-adjustment. Carbon-Filled Teflon® utilised as it is stiffer, has a higher temperature limit and does not cold-flow.

10 Solid Zirconia-Toughened Alumina Body fully encapsulates the ball and acts as the pressure containing vessel when assembled with the socket. This ensures that aggressive fluids do not come in contact with any of the external stainless steel components. ZTA ensures increased mechanical strength and fracture toughness over alumina, and has high temperature stability and corrosion resistance.

11 Solid Cerium-Stabilised Zirconia Ball resists corrosion and abrasion and is offered in a variety of equal-percent and round ported styles. Floating-ball design requires reduced actuation torque and minimizes the possibility of fracture due to over-torquing. Having a minimal amount of dead space allows the ability to handle high differentials, as well as having abundant strength to withstand any surface particulate accumulation. Ce-TZP ceramic is utilised as standard for the ceramic ball, as this component needs to be extremely strong, wear-resistant, chemically inert, have a fracture toughness of a high level and resistance to degradation at low temperatures.

12 Hastelloy-C® Stem offers excellent corrosion-resistant properties and sufficient hardness to drive the ball indefinitely. Standard stem may be replaced with virtually any material to maximize process compatibility and longevity.

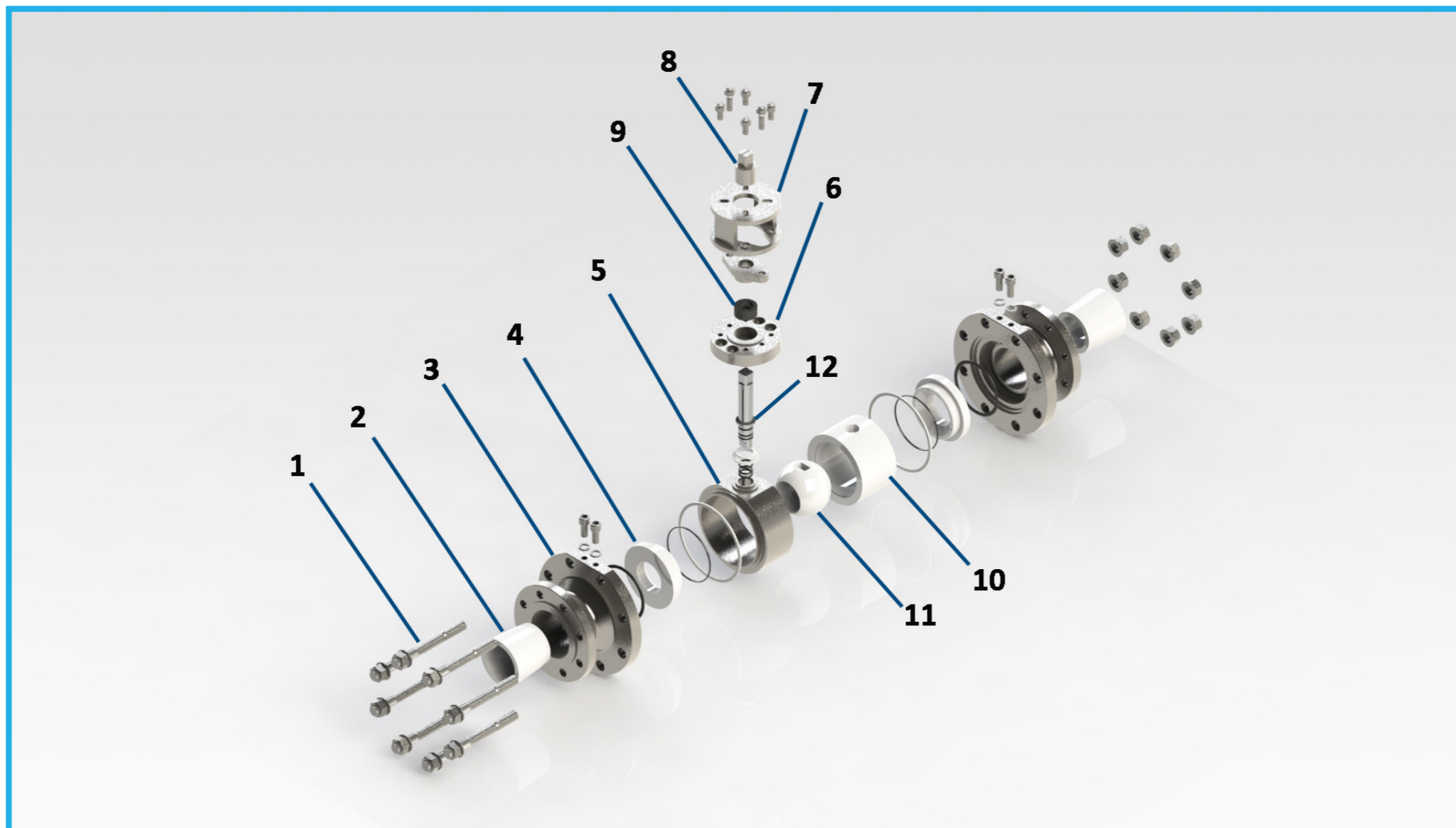

Technical

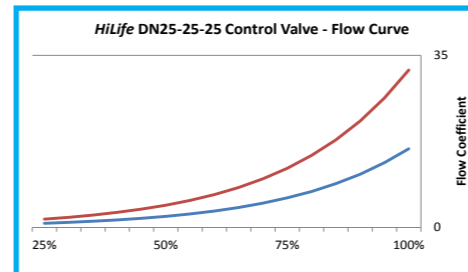
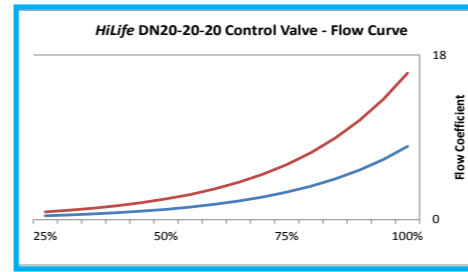
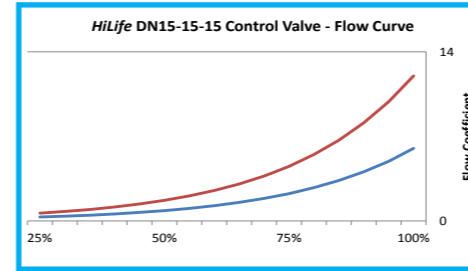
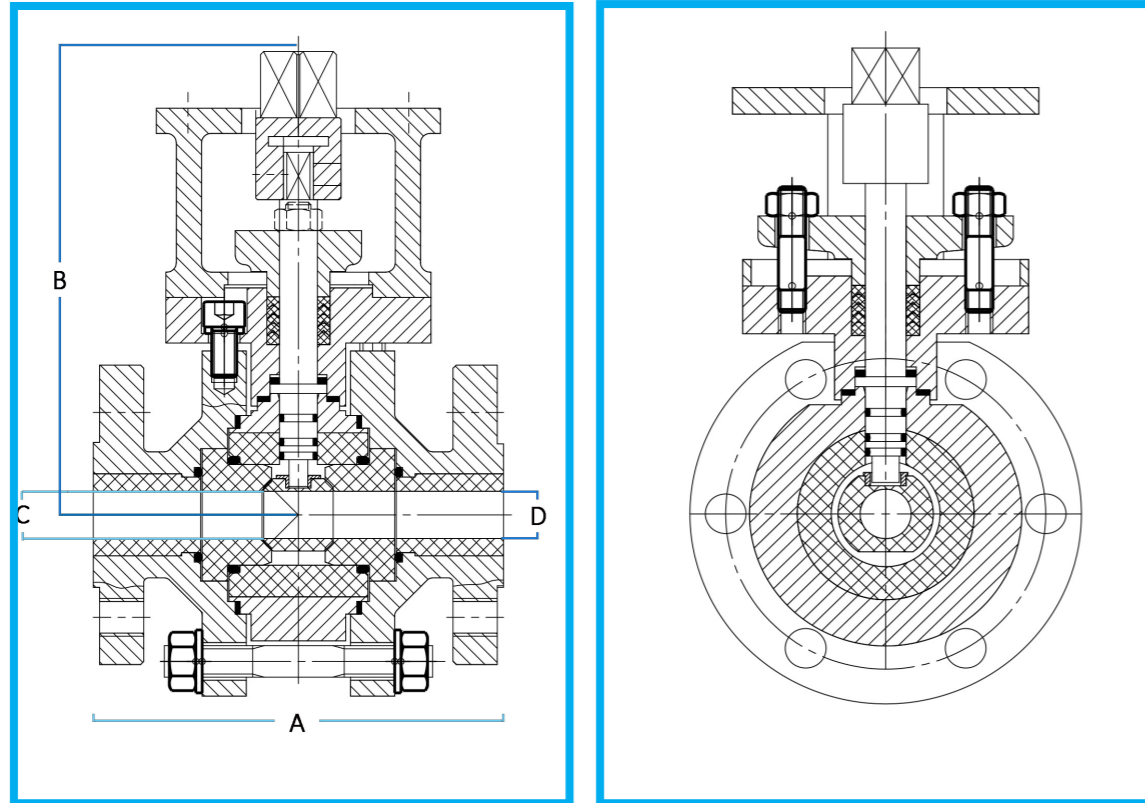

Bore Size	Cv Factor		
	Round Port	30 Degree EQ%	60 Degree EQ%
DN 15-15-15	23	6	12
DN 20-20-20	44	8	16
DN 25-25-25	84	16	32
DN 40-25-40	84	16	32
DN 40-40-40	200	24	78
DN 50-40-50	200	24	78
DN 50-50-50	250	56	90
DN 65-40-65	200	24	78
DN 65-65-65	444	78	160
DN 80-65-80	444	78	160
DN 80-80-80	643	86	250
DN 100-80-100	643	86	250
DN 100-100-100	1041	198	450
DN 150-100-150	1041	198	450
DN 150-150-150*	1890	350	800

* For further information contact Carlen

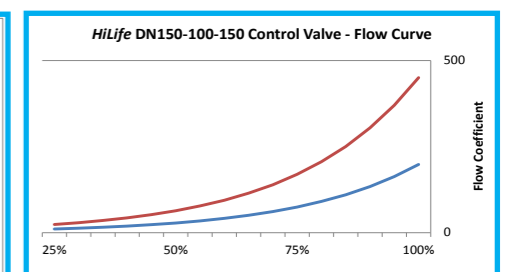
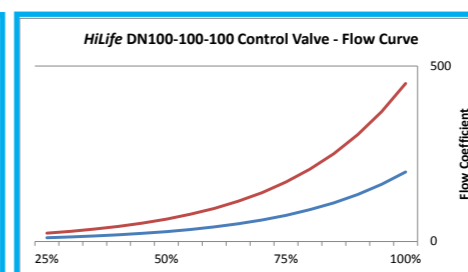
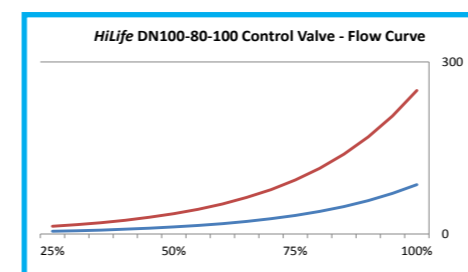
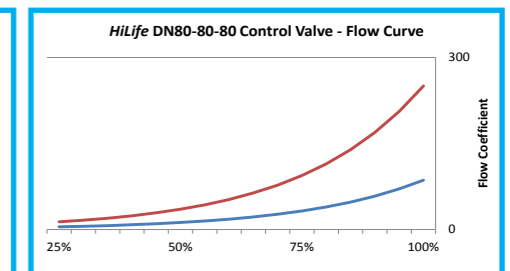
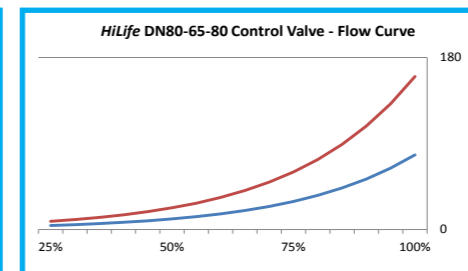
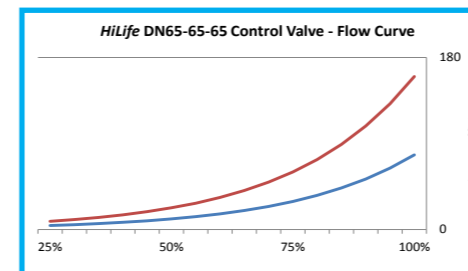
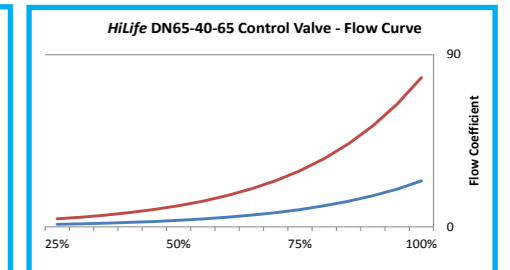
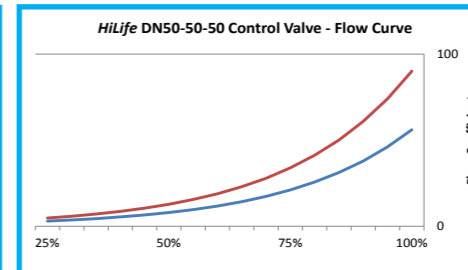
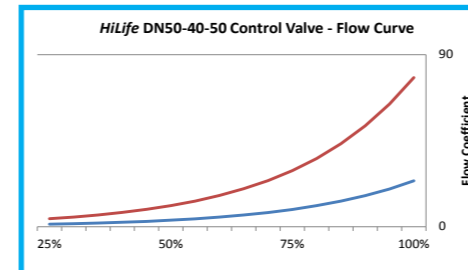
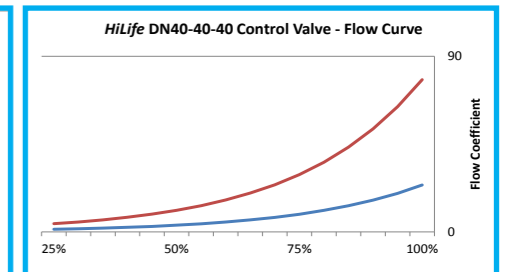
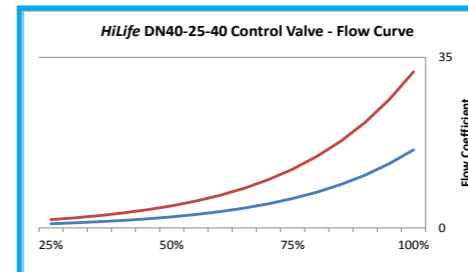

HiLife Technical Dimensions [metric/imperial]									
	A		B		C		D		
	mm	in	mm	in	mm	in	mm	in	
DN 15-15-15	130	5.1"	130	5.1"	15	5/8"	15	5/8"	
DN 20-20-20	150	5.9"	148	5.8"	20	3/4"	20	3/4"	
DN 25-25-25	160	6.2"	137	5.3"	25	1"	25	1"	
DN 40-25-40	200	7.8"	142	5.5"	25	1"	40	1.5"	
DN 40-40-40	200	7.8"	162	6.3"	40	1.5"	40	1.5"	
DN 50-40-50	230	9"	162	6.3"	40	1.5"	50	2"	
DN 50-50-50	230	9"	210	8.2"	50	2"	50	2"	
DN 65-40-65	290	11.4"	144	5.6"	40	1.5"	65	2.5"	
DN 80-65-80	310	12.2"	217	8.5"	65	2.5"	80	3"	
DN 80-80-80	310	12.2"	265	10.4"	80	3"	80	3"	
DN 100-80-100	350	13.7"	246	9.6"	80	3"	100	4"	
DN 100-100-100	350	13.7"	330	12.9"	100	4"	100	4"	
DN 150-100-150	480	18.8"	387	15.2"	100	4"	150	6"	
DN 150-150-150	480	18.8"	450	17.7"	150	6"	150	6"	

*Specifications and dimensions are subject to change without notice. Please contact Carlen for full specification details at the time of enquiry.

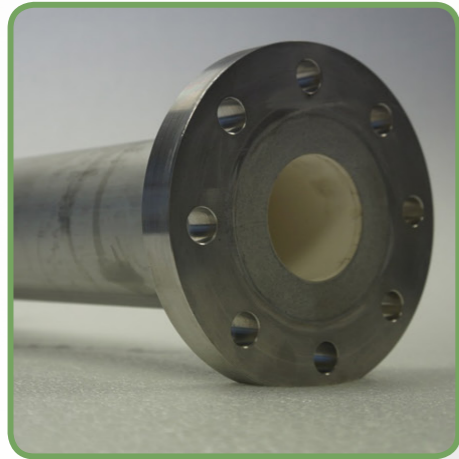

Carten Ceramic spools are utilised to protect customer systems where abrasion can be at it's highest level – post the control valve installation, where high-velocity media streams can cause high levels of wear. This protects the customer core piping system with our 95% Alumina ceramic, and can be assembled without disrupting the pipelines

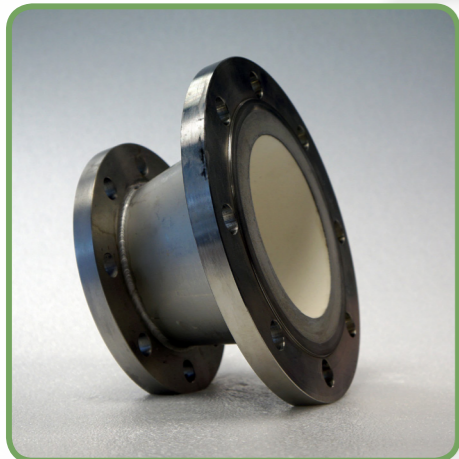

Features of Carten Ceramic Lined Spools and Reducers

Ceramic have excellent mechanical properties.

Corrosion-Resistant: Ceramic lined spools and reducers are designed with higher endurance than spools lined with glass, rubber or plastics. They have a high endurance to most chemicals, including strong acids and alkalis.

Abrasion Resistant: Ceramics are almost equivalent to diamonds in terms of hardness and they are highly resistant to wear.

Cavitation Resistant: Unlike stainless steel, they can handle continuous cavitation without cracking or wearing down.



Ceramic spools and reducers are **not affected by changes in the pressure** across the valve. Zirconia along with a number of other materials offers **high thermal shock resistance**.

Applications

Ceramic Lined Spools and Reducers are chosen due to their immense corrosive and abrasive resistance, hardness and elasticity. The high strength of ceramics is maintained at high temperatures and high abrasiveness. This is a distinguishing factor when replacing the majority of metals, glasses, plastics, etc.

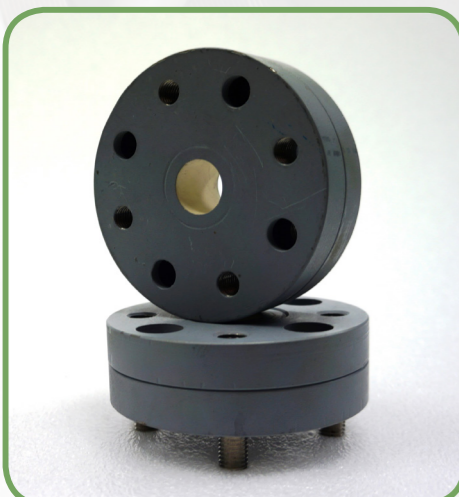

Variations:

Carten can supply thin-dimension ceramic adaptors that allow the customer to meet small gaps in pipeline, or achieve standard lengths. In addition, Carten's unique design allows the user to maintain the orientation of the current pipeline bolting.

Top Works

Carten HiLife Ceramic Ball Valve compatible with all major brands*



All Carten HiLife valves include a stainless steel bracket, or yoke interface, and coupling which meet the dimensional standards of ISO 5211 and provide a compact and direct fit onto most rotary actuator brands and models including electric and pneumatic. There are many different options for our top works including pressure reducing regulators, electro pneumatic positioners (smart, analogue), solenoid valves and limit switches.

*All accessories (eg. Positioner, actuator, limit switch, etc.) which are included with the HiLife valves to be marketed in the EU, have acquired the CE mark where appropriate.

Other Products in the HiLife Series

Carten's HiLife series features a zirconia (ZTA) ceramic liner and disc, to outperform valves with conventional alloy trim. Zirconia ceramic exhibits 2.5 times the fracture toughness of any alumina, nitride, or carbide ceramic, and is 12 times more wear resistant than stainless steel. The fully lined ceramic valve ensures reliable, consistent control together with high wear resistance.

Gate Valves



1. Surface sealed with structural ceramic to resist abrasion and scratching
2. Plate design for wear resistance and effective sealing
3. Low pressure bi-directional sealing without blockage or ash accumulation
4. Technical Specification: Suitable for pneumatic conveying systems containing highly abrasive media such as powder or tiny solid particles.
5. Up to ANSI FCI 70/2 Class VI leakage available.
6. Multiple ANSI and DIN flange standards available. ANSI 150 and 300 classes are also available.

Butterfly Valves

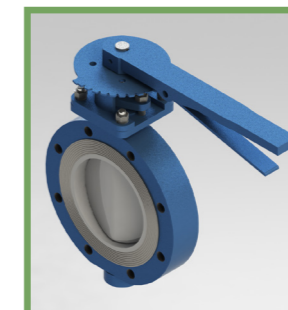

1. Excellent, cost effective control valve for aggressive media
2. Eliminates characteristic problems of butterfly valves in abrasive media - disc wear
3. Ceramics are nearly universally chemical inert
4. Full control options, including 4-20mA positioner and actuator
5. Multiple ANSI and DIN flange standards available. ANSI 150 and 300 classes are also available

HiLife Product Description

0 CHL - **1** CBV1 **2** D - **3** P **4** S **5** D **6** H - **7** E **8** 24 - **9** F07 - **10** ZTA

No.	Meaning	Supplementary Explanation																																																																						
0	Carten HiLife	CHL																																																																						
1	Ceramic Ball Valve	CBV1																																																																						
2	Action Type None D: Direct Action (Air to close) R: Reverse Action (Air to Open)	- D R																																																																						
3	Positioner None (No Positioner) P: Pneumatic Positioner E: Electropneumatic Smart S1: Solenoid	- P E S1																																																																						
4	Actuator None (No Actuator) D: Double Acting S: Spring Back M: Motorised	- D S M																																																																						
5	Applied Standard for Flange J: JIS10k A: ANSI 150 A3: ANSI 300 D: DIN PN16	J A A3 D																																																																						
6	Nominal Diameter D: 15A 1/2" E: 20A 3/4" F: 25A 1" H: 40A 1 1/2" I: 50A 2" J: 65A 2 1/2" K: 80A 3" M: 100A 4" O: 150A 6"	D E F H I J K M O																																																																						
7	Valve Characteristic E: EQ% O: ON/OFF L: Linear	E O L																																																																						
8	Cv (What Cv value do you require?)	<table border="1"> <thead> <tr> <th>DN</th> <th>Round Port</th> <th>30° EQ%</th> <th>60° EQ%</th> <th>DN</th> <th>Round Port</th> <th>30° EQ%</th> <th>60° EQ%</th> </tr> </thead> <tbody> <tr> <td>15-15-15</td> <td>23</td> <td>6</td> <td>12</td> <td>65-65-65</td> <td>444</td> <td>78</td> <td>160</td> </tr> <tr> <td>20-20-20</td> <td>44</td> <td>8</td> <td>16</td> <td>80-65-80</td> <td>444</td> <td>78</td> <td>160</td> </tr> <tr> <td>25-25-25</td> <td>84</td> <td>16</td> <td>32</td> <td>80-80-80</td> <td>643</td> <td>86</td> <td>250</td> </tr> <tr> <td>40-25-40</td> <td>84</td> <td>16</td> <td>32</td> <td>100-80-100</td> <td>643</td> <td>86</td> <td>250</td> </tr> <tr> <td>40-40-40</td> <td>200</td> <td>24</td> <td>78</td> <td>100-100-100</td> <td>1041</td> <td>198</td> <td>450</td> </tr> <tr> <td>50-40-50</td> <td>200</td> <td>24</td> <td>78</td> <td>150-100-150</td> <td>1041</td> <td>198</td> <td>450</td> </tr> <tr> <td>50-50-50</td> <td>250</td> <td>56</td> <td>90</td> <td colspan="3">*DN150 and above contact Carten</td> </tr> <tr> <td>65-40-65</td> <td>200</td> <td>24</td> <td>78</td> <td colspan="3"></td> </tr> </tbody> </table>	DN	Round Port	30° EQ%	60° EQ%	DN	Round Port	30° EQ%	60° EQ%	15-15-15	23	6	12	65-65-65	444	78	160	20-20-20	44	8	16	80-65-80	444	78	160	25-25-25	84	16	32	80-80-80	643	86	250	40-25-40	84	16	32	100-80-100	643	86	250	40-40-40	200	24	78	100-100-100	1041	198	450	50-40-50	200	24	78	150-100-150	1041	198	450	50-50-50	250	56	90	*DN150 and above contact Carten			65-40-65	200	24	78			
DN	Round Port	30° EQ%	60° EQ%	DN	Round Port	30° EQ%	60° EQ%																																																																	
15-15-15	23	6	12	65-65-65	444	78	160																																																																	
20-20-20	44	8	16	80-65-80	444	78	160																																																																	
25-25-25	84	16	32	80-80-80	643	86	250																																																																	
40-25-40	84	16	32	100-80-100	643	86	250																																																																	
40-40-40	200	24	78	100-100-100	1041	198	450																																																																	
50-40-50	200	24	78	150-100-150	1041	198	450																																																																	
50-50-50	250	56	90	*DN150 and above contact Carten																																																																				
65-40-65	200	24	78																																																																					
9	Stainless Steel Bracket Standard Call outs shown, Additional Options available on request	F05 F07 F10 F12 F14																																																																						
10	Specification KA: Kalrez O-Rings FKJ: Standard Raised Face Flange CR: Ceramic Lined Reducer CP: Ceramic Lined Spool HAN: Manual Handle GO: Gear Operated ZTA: Zirconia Toughened Alumina	KA FKJ CR CP HAN GO ZTA																																																																						

PED Certification*

In the case that the product specifications or the precautions outlined in the instruction manual are not followed, the product may not be covered by the PED. Therefore customers are responsible for correct operation of the product in order to ensure its safe use within the limits of PED. Carten Controls is certified to the European Pressure Equipment Directive, Ref. 97/23/EC, through the monitoring from the National Standards Authority of Ireland (N.S.A.I). Product bears the notified body number (or CE mark identification) 0050 where applicable. HiLife valves produced in Carten, are certified to bear this mark through annual assessment by the N.S.A.I under Module D1; Production Quality Control.

As part of the certification process, the Carten HiLife series is designed and manufactured in full compliance with ASME B16.34 Carten Controls Ltd. is an IS EN ISO 9001:2008 registered and certified company, and its quality systems are monitored by the National Standards Authority of Ireland (N.S.A.I).

Pressure	Size	Fluid Group			
		Group 1 Liquid	Group 2 Liquid	Group 1 Gas	Group 2 Gas
10 bar and Under	≤25A	SEP	SEP	SEP	SEP
	>25A ; ≤100A	SEP	SEP	I	SEP
	150A	SEP	SEP	II	SEP (6 bar and under) I

The table above illustrates which Pressure Equipment Directive (PED - CE) category is applicable to a HiLife valve dependent on its maximum pressure, nominal size and operating fluid group. Note; Fluid group classification as per PED 97/23/EC.

*For additional certification requests contact Carten

Customer Order Requirements

1. All Valves

(Please enter your requirements below)

Media	Characteristic/Particle Size/Media Type	
Mass Density	Calculated using Specific Gravity	
Media Flow	Flow velocity of system (m3 / h)	
Upstream Pressure	Pressure maintained at Valve Inlet (MPa)	
Downstream Pressure	Pressure maintained at Valve Outlet (MPa)	
Delta P	Differential Pressure Across Valve (MPa)	
Ball Trim/Valve Function	Control or Shut-Off Function	
Pressure Rating	Maximum Shell Rating of Valve	
Operating Temperature	Maximum Temperature of Media	
Differential Temperature	Max. Allowed Temperature Differential (°C)	
Flange Connection	Type of Connection (ANSI, DIN etc)	
Cv Calculation	Flow Capacity of Customer System	
Face-to-Face Length	Standard for OAL	

2. Control Valves

Control Range	Rangeability of Valve to Control Flow	
Minimum Cv Calculation	To Ensure System Flow can be Controlled	

3. Automation - Actuators

Actuation Type	Double-Acting, Spring-Return, Electric	
Actuation Mode	Reverse (NC), Direct (NO)	
Failure Position	Signal Failure Position	
Actuator Force/Sizing	Connection Data, Rotational Torque Force	
Instrument Control	What pressure, electric signal is available	
Pressure Reducing Regulator	To Enable Control of Actuator Thrust	

4. Automation - Positioners

Signal Type	SMART, Analogue, Pneumatic	
Protection Class	ATEX, Ex, PED etc	

PED

For further information please contact:

CARTEN[®]

High Performance Valves & Flow Solutions

In Europe:

Carten Controls Ltd.,
Unit 609, Waterford Industrial Park,
Waterford, Ireland.

Tel: +353 (0)51355436

Fax: +353 (0)51378054

Email: sales@cartencontrols.com

Website: <http://www.cartencontrols.com>

In America:

Carten Fujikin Inc,
604 West Johnson Avenue,
Cheshire, Connecticut,
CT 06410, USA.

Tel: + 1-203-699-2134

Fax: + 1-203-699-2179

Email: sales@cartenus.com

Web: www.cartenus.com

Fujikin[®]

Fujikin (Deutschland) GmbH
Immermannstraße 33 -
D-40210 Düsseldorf, Germany.

Tel: +49 (0) 211-350458

Fax: +49 (0) 211-363990

Email: info@fujikin.de

Website: <http://www.fujikin.de>

ISO9001

ASME B16.34

LEAKAGE CLASS V

PN 16

CERIUM STABILISED ZIRCONIA

CARTEN HiLife